

CABLE DRAG CHAIN SYSTEMS

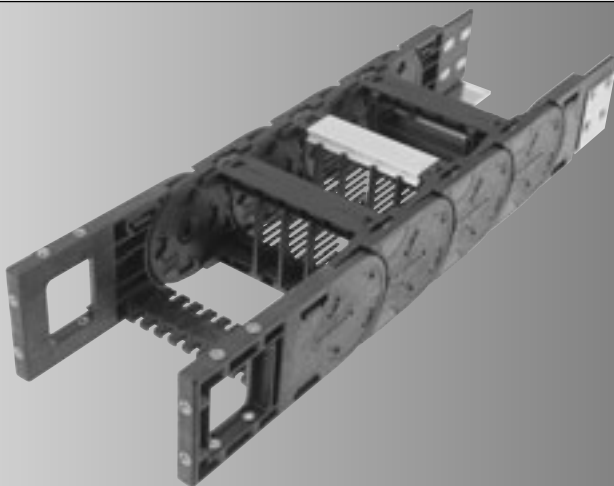

HeavyLine

MP 62.2



MP 62.2 - HeavyLine

Order variants

Style (order code)									
Configuration (order code) * = standard									
Radius (order code)									
in mm									
Internal width (order code)									
in mm									
External width									
in mm									
MP 62.2 118	150	118	118						
MP 62.2 143	175	143	143						
MP 62.2 168	200	168	168						
MP 62.2 193	225	193	193						
MP 62.2 218	250	218	218						
MP 62.2 243	275	243	243						
MP 62.2 268	300	268	268						
MP 62.2 293	325	293	293						0
MP 62.2 318	350	318	318						1
MP 62.2 343	375	343	343						2*
MP 62.2 368	400	368	368	150	150				3*
MP 62.2 418	450	418	418	200	200				4
MP 62.2 468	500	468	468	250	250				5
MP 62.2 518	550	518	518	300	300				6
MP 62.2 xxx	Inside	>118-	518	400	400				7
	+ 32	600	ALU	500	500				9

Order number:

Configuration:

- 0 crossbar every link; w/bias
- 1 crossbar every link; w/o bias
- 2* crossbar EOL; w/bias
- 3* crossbar EOL; w/o bias
- 4 AL crossbar every link; w/bias
- 5 AL crossbar every link; w/o bias
- 6 AL crossbar EOL; w/bias
- 7 AL crossbar EOL; w/o bias
- 9 Customer order

Style:

- 0 Standard (PA)
- 7 ESD (PA)
- 9 Special version

Sample order

0622 118 150 0000

Inside width = 118 mm

Radius = 150 mm

Configuration = 0

Style = 0

Ideal operating conditions

- Extreme accelerations
- Extreme speeds
- Very high additional loads
- Opens on both sides
- Variable widths thanks to aluminium ridge
- Flexible internal separation
- Variant with/without bias

Alternative chain type

- MP 65 G closed series
- MP 66 easier to use
- MP 62.1 higher unsupported length

Features

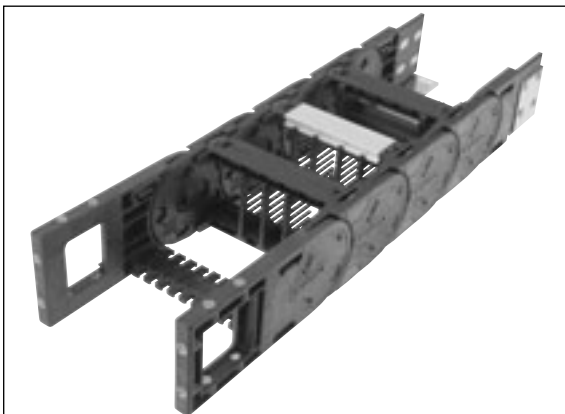

Chain bracket with fixing means on three sides



Chain bracket with variably positionable metal bracket



Frame ridge strain relief can be integrated into chain bracket



Frame ridges / covers in inside and outside bend can be removed



Side links with CLICK lock for easy opening



Radii with or without bias (RK/RV)



ESD cable drag chains for use in areas at risk of explosion



Back radius combinations



Aluminium frame ridges with integrated lock grid in variable lengths



Foldable shelf system for reliable cable guidance

MP 62.2 - HeavyLine

Technical data

Chain link dimensions

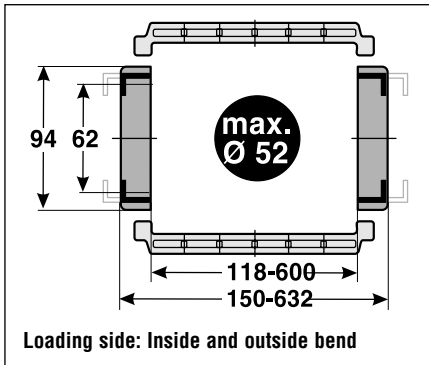

Material properties

Service temperature: -30 to +120 °C
 Gliding friction factor: 0.30
 Static friction factor: 0.45
 Fire classification: VDE 0304 IIC; UL94 HB
 ESD material: CE Ex II 2 GD
 Other material properties on request

Technical specifications

Travel distance, gliding, L_g : 180 m
 Travel distance, self-supporting, L_s : see diagram
 Travel distance, vertical, hanging, L_{vh} : 120 m
 Travel distance, vertical, upright, L_{vu} : 6 m
 Rotated 90°, self-supporting, L_{sg} : 4 m
 Speed, gliding, V_g : 5 m/s
 Speed, self-supporting, V_s : 20 m/s
 Acceleration, gliding, a_g : 25 m/s²
 Acceleration, self-supporting, a_s : 40 m/s²

Unsupported length

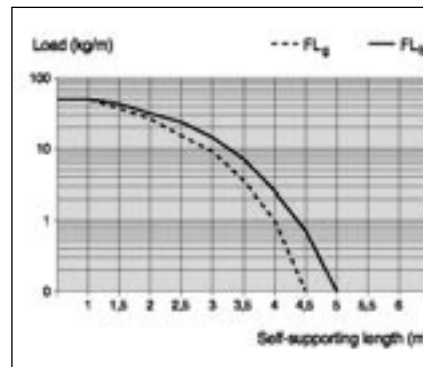
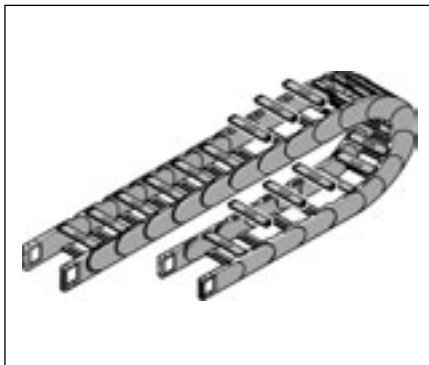

FL_g:
 Ideal installation situation for high stresses at the limit of the max. travel parameters. In this range the chain upper run is still biased, straight or has a max. sag of 10 – 50 mm depending on the type of chain.

FL_s:
 Satisfactory installation position for many applications working in the lower to middle range of the max. travel parameters. Depending on the chain type, the sag of the chain upper run is > 10 – 50 mm but less than the max. sag.

If the sag is greater than FL_s, the arrangement is unsuitable and should be avoided. Please choose a more stable murrplastik cable drag chain.

Determining the chain length

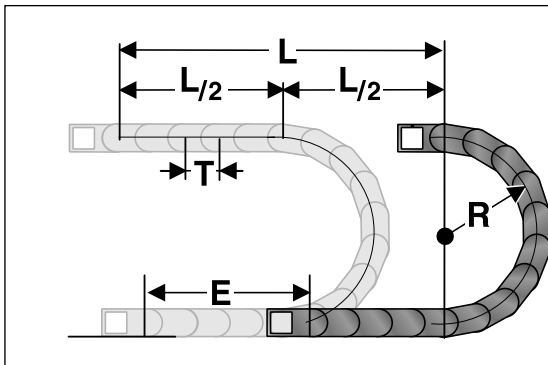

L = Travel distance
 R = Radius
 T = Pitch
 E = Distance between entry point and middle of travel distance

Determining the chain length

$$\text{Length} = \frac{L}{2} + \pi \times R + E$$

≈ 1 m chain = 10 x 100 mm links

The fixed point of the cable drag chain should be connected in the middle of the travel distance. This arrangement gives the shortest connection between the fixed point and the moving consumer and thus the most efficient chain length.

Installation dimensions (in mm)

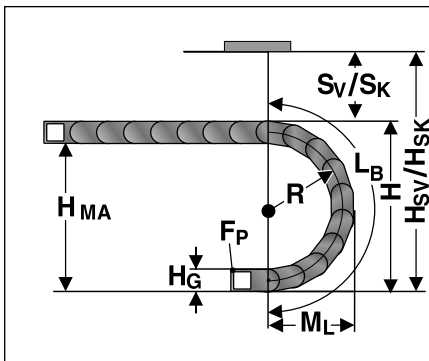

Radius R	150	200	250	300	400	500
Outside height of chain link (H_c)	94	94	94	94	94	94
Height of bend (H)	394	494	594	694	894	1094
Height of moving end connection (H_{MA})	300	400	500	600	800	1000
Safety margin with bias (S_v)	50	50	50	50	50	50
Installation height with bias (H_{sv})	444	544	644	744	944	1144
Safety margin without bias (S_k)	20	20	20	20	20	20
Installation height without bias (H_{sk})	414	514	614	714	914	1114
Arc projection (M_l)	297	347	397	447	547	647
Bend length (L_b)	719	876	1033	1190	1504	1818



MP 62.2 - HeavyLine

Chain bracket

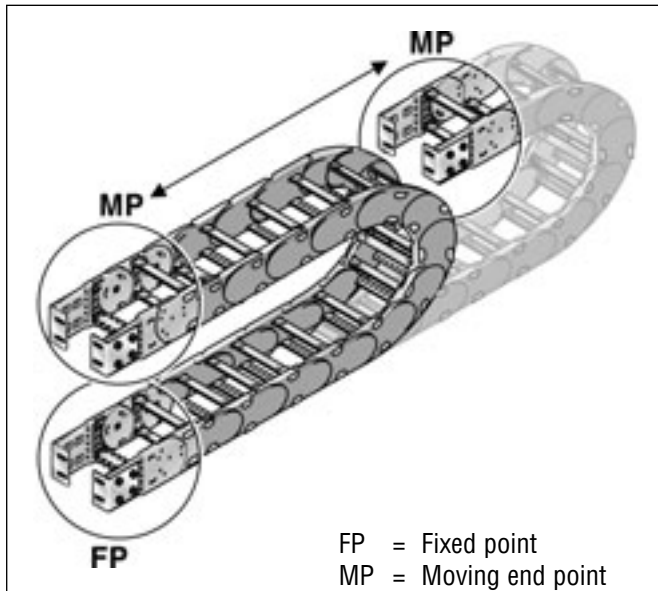

Chain bracket flexible

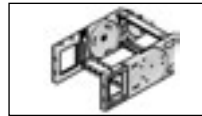

Flexible

Chain bracket elbow fitting

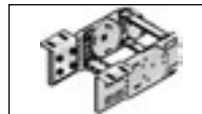

Top / outside



Front / outside



Bottom / outside

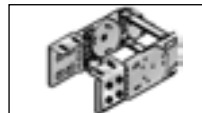

Top / inside

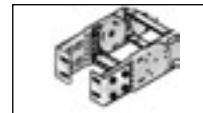

Front / inside

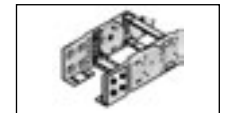

Bottom / inside

Chain bracket flexible

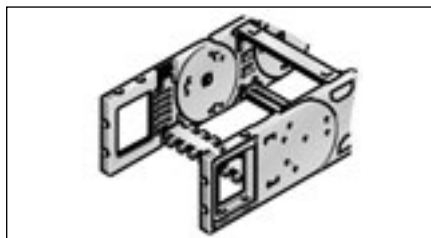

Type	Order no.	Version	Pack
KA 62-FB Female end	0620000056	with bush	1
KA 62-FB Male end	0620000057	with bush	1
KA 62-FG Female end	0620000058	with thread	1
KA 62-FG Male end	0620000059	with thread	1

This chain bracket offers universal connection options (top, bottom and front) and is attached to the ends of the chain like a side link. This allows the chain to move right up to the bracket. Each chain requires one male and one female bracket. M8 screws are used to secure the brackets in place. Extrusion coated metal bushes with either a through-hole (-FB) or a threaded hole (-FG) ensure the permanent, high-strength transmission of even extreme forces onto the cable drag chain.

Chain bracket elbow fitting

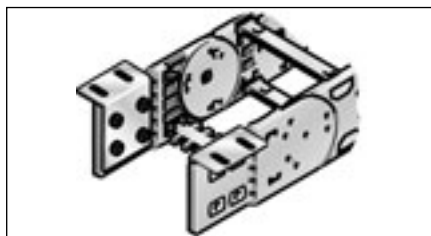

Type	Order no.	Pack
KA 62 Female end	0620000050	1
KA 62 Male end	0620000051	1

This chain bracket offers universal connection options (top, bottom and front) and is attached to the ends of the chain like a side link. This allows the chain to move right up to the bracket. Each chain requires one male and one female bracket. M8 screws are used to secure the brackets in place. Metal inserts (supplied) help to minimise the cold flow properties. This is an enormous advantage, guaranteeing the smooth transfer of high loads to the chain.

MP 62.2 - HeavyLine

Chain bracket flexible

Dimensions in mm

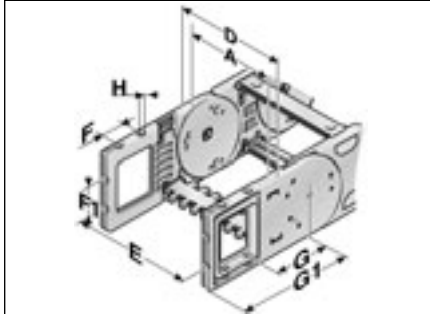

Flexible with through-hole

Type	A	D	E	F	F1	G	G1	H Ø
KA 62-FB	118.00	150.00	135.00	35.00	45.00	107.00	171.50	8.50
KA 62-FB	143.00	175.00	160.00	35.00	45.00	107.00	171.50	8.50
KA 62-FB	168.00	200.00	185.00	35.00	45.00	107.00	171.50	8.50
KA 62-FB	193.00	225.00	210.00	35.00	45.00	107.00	171.50	8.50
KA 62-FB	218.00	250.00	235.00	35.00	45.00	107.00	171.50	8.50
KA 62-FB	243.00	275.00	260.00	35.00	45.00	107.00	171.50	8.50
KA 62-FB	268.00	300.00	285.00	35.00	45.00	107.00	171.50	8.50
KA 62-FB	293.00	325.00	310.00	35.00	45.00	107.00	171.50	8.50
KA 62-FB	318.00	350.00	335.00	35.00	45.00	107.00	171.50	8.50
KA 62-FB	343.00	375.00	360.00	35.00	45.00	107.00	171.50	8.50
KA 62-FB	368.00	396.00	385.00	35.00	45.00	107.00	171.50	8.50
KA 62-FB	418.00	450.00	435.00	35.00	45.00	107.00	171.40	8.50
KA 62-FB	468.00	500.00	485.00	35.00	45.00	107.00	171.40	8.50
KA 62-FB	518.00	550.00	535.00	35.00	45.00	107.00	171.40	8.50
KA 62-FB	Variable	A+32.00	A+17.00	35.00	45.00	107.00	171.50	8.50

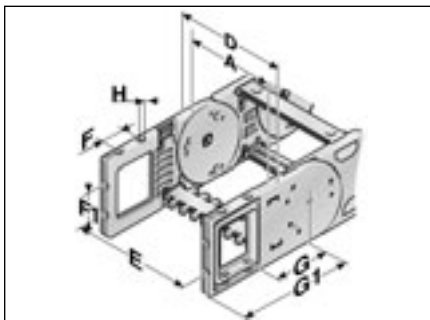

Flexible with threaded bush

Type	A	D	E	F	F1	G	G1	H
KA 62-FG	118.00	150.00	135.00	35.00	45.00	107.00	171.50	M8
KA 62-FG	143.00	175.00	160.00	35.00	45.00	107.00	171.50	M8
KA 62-FG	168.00	200.00	185.00	35.00	45.00	107.00	171.50	M8
KA 62-FG	193.00	225.00	210.00	35.00	45.00	107.00	171.50	M8
KA 62-FG	218.00	250.00	235.00	35.00	45.00	107.00	171.50	M8
KA 62-FG	243.00	275.00	260.00	35.00	45.00	107.00	171.50	M8
KA 62-FG	268.00	300.00	285.00	35.00	45.00	107.00	171.50	M8
KA 62-FG	293.00	325.00	310.00	35.00	45.00	107.00	171.50	M8
KA 62-FG	318.00	350.00	335.00	35.00	45.00	107.00	171.50	M8
KA 62-FG	343.00	375.00	360.00	35.00	45.00	107.00	171.40	M8
KA 62-FG	368.00	396.00	385.00	35.00	45.00	107.00	171.40	M8
KA 62-FG	418.00	450.00	435.00	35.00	45.00	107.00	171.40	M8
KA 62-FG	468.00	500.00	485.00	35.00	45.00	107.00	171.40	M8
KA 62-FG	518.00	550.00	535.00	35.00	45.00	107.00	171.40	M8
KA 62-FG	Variable	A+32.00	A+17.00	35.00	45.00	107.00	171.50	M8



MP 62.2 - HeavyLine

Chain bracket elbow fitting

Dimensions in mm

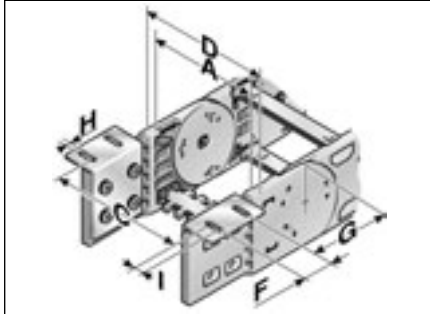

Bottom and top / outside

Type	A	C	D	F	G	H Ø	I
KA 62	118.00	162.00	150.00	45.00	102.00	9.00	15.00
KA 62	143.00	187.00	175.00	45.00	102.00	9.00	15.00
KA 62	168.00	212.00	200.00	45.00	102.00	9.00	15.00
KA 62	193.00	237.00	225.00	45.00	102.00	9.00	15.00
KA 62	218.00	262.00	250.00	45.00	102.00	9.00	15.00
KA 62	243.00	287.00	275.00	45.00	102.00	9.00	15.00
KA 62	268.00	312.00	300.00	45.00	102.00	9.00	15.00
KA 62	293.00	337.00	325.00	45.00	102.00	9.00	15.00
KA 62	318.00	362.00	350.00	45.00	102.00	9.00	15.00
KA 62	343.00	387.00	375.00	45.00	102.00	9.00	15.00
KA 62	368.00	412.00	400.00	45.00	102.00	9.00	15.00
KA 62	418.00	462.00	450.00	45.00	102.00	9.00	15.00
KA 62	468.00	512.00	500.00	45.00	102.00	9.00	15.00
KA 62	518.00	562.00	550.00	45.00	102.00	9.00	15.00
KA 62	Variable	A+44.00	A+32.00	45.00	102.00	9.00	15.00

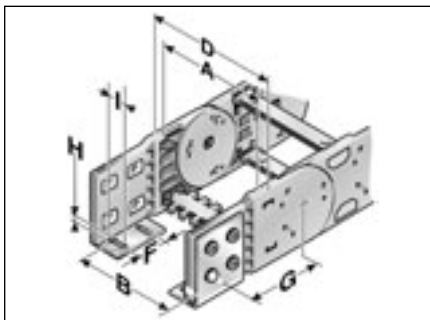

Bottom and top / inside

Type	A	B	D	F	G	H Ø	I
KA 62	118.00	106.00	150.00	45.00	102.00	9.00	15.00
KA 62	143.00	131.00	175.00	45.00	102.00	9.00	15.00
KA 62	168.00	156.00	200.00	45.00	102.00	9.00	15.00
KA 62	193.00	181.00	225.00	45.00	102.00	9.00	15.00
KA 62	218.00	206.00	250.00	45.00	102.00	9.00	15.00
KA 62	243.00	231.00	275.00	45.00	102.00	9.00	15.00
KA 62	268.00	256.00	300.00	45.00	102.00	9.00	15.00
KA 62	293.00	281.00	325.00	45.00	102.00	9.00	15.00
KA 62	318.00	308.00	350.00	45.00	102.00	9.00	15.00
KA 62	343.00	331.00	375.00	45.00	102.00	9.00	15.00
KA 62	368.00	356.00	400.00	45.00	102.00	9.00	15.00
KA 62	418.00	406.00	450.00	45.00	102.00	9.00	15.00
KA 62	468.00	456.00	500.00	45.00	102.00	9.00	15.00
KA 62	518.00	506.00	550.00	45.00	102.00	9.00	15.00
KA 62	Variable	A-12.00	A+32.00	45.00	102.00	9.00	15.00

MP 62.2 - HeavyLine

Chain bracket elbow fitting

Dimensions in mm

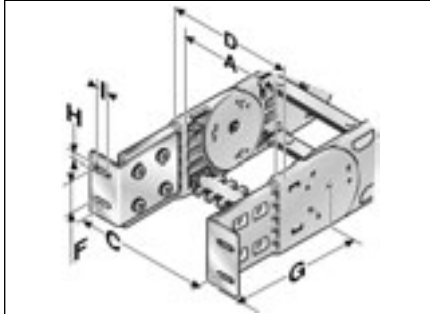

Front / outside

Type	A	C	D	F	G	H Ø	I
KA 62	118.00	162.00	150.00	45.00	171.50	9.00	15.00
KA 62	143.00	187.00	175.00	45.00	171.50	9.00	15.00
KA 62	168.00	212.00	200.00	45.00	171.50	9.00	15.00
KA 62	193.00	237.00	225.00	45.00	171.50	9.00	15.00
KA 62	218.00	262.00	250.00	45.00	171.50	9.00	15.00
KA 62	243.00	287.00	275.00	45.00	171.50	9.00	15.00
KA 62	268.00	312.00	300.00	45.00	171.50	9.00	15.00
KA 62	293.00	337.00	325.00	45.00	171.50	9.00	15.00
KA 62	318.00	362.00	350.00	45.00	171.50	9.00	15.00
KA 62	343.00	387.00	375.00	45.00	171.50	9.00	15.00
KA 62	368.00	412.00	400.00	45.00	171.50	9.00	15.00
KA 62	418.00	462.00	450.00	45.00	171.50	9.00	15.00
KA 62	468.00	512.00	500.00	45.00	171.50	9.00	15.00
KA 62	518.00	562.00	550.00	45.00	171.50	9.00	15.00
KA 62	Variable	A+44.00	A+32.00	45.00	171.50	9.00	15.00

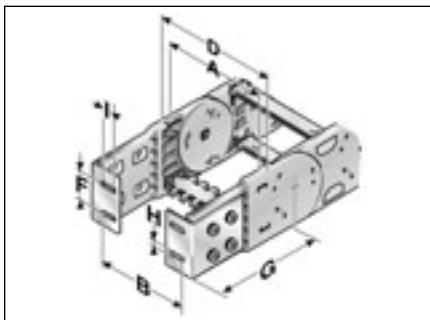

Front / inside

Type	A	B	D	F	G	H Ø	+I
KA 62	118.00	106.00	150.00	45.00	171.50	9.00	15.00
KA 62	143.00	131.00	175.00	45.00	171.50	9.00	15.00
KA 62	168.00	156.00	200.00	45.00	171.50	9.00	15.00
KA 62	193.00	181.00	225.00	45.00	171.50	9.00	15.00
KA 62	218.00	206.00	250.00	45.00	171.50	9.00	15.00
KA 62	243.00	231.00	275.00	45.00	171.50	9.00	15.00
KA 62	268.00	256.00	300.00	45.00	171.50	9.00	15.00
KA 62	293.00	281.00	325.00	45.00	171.50	9.00	15.00
KA 62	318.00	308.00	350.00	45.00	171.50	9.00	15.00
KA 62	343.00	331.00	375.00	45.00	171.50	9.00	15.00
KA 62	368.00	356.00	400.00	45.00	171.50	9.00	15.00
KA 62	418.00	406.00	450.00	45.00	171.50	9.00	15.00
KA 62	468.00	456.00	500.00	45.00	171.50	9.00	15.00
KA 62	518.00	506.00	550.00	45.00	171.50	9.00	15.00
KA 62	Variable	A-12.00	A+32.00	45.00	171.50	9.00	15.00



MP 62.2 - Accessories

Separator



Separator

Type	Order no.	Description	Pack
TR 62	062000009200	Separator	1

Lock grid spacing 5.00 mm

We recommend that separators are used if multiple round cables or conduits with differing diameters are to be installed. An offset configuration of the separators is advisable.

Type	Dimensions in mm							
	TI	H	H1	H2	H3	H4	H5	HI

TR 62	3.50	5.50	12.10	20.10	28.70	37.00	45.30	62.80
-------	------	------	-------	-------	-------	-------	-------	-------

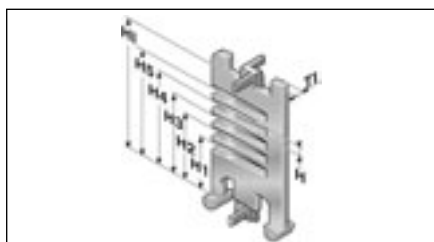

Separator

Shelving system

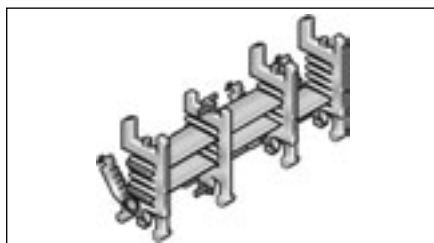

Shelving system

Type	Order no.	Description	Width in mm	Pack
RB 056-7	100000005600	RB 056-7 Shelf	56	1
RB 066-7	100000006600	RB 066-7 Shelf	66	1
RB 081-7	100000008100	RB 081-7 Shelf	81	1
RB 106-7	100001000600	RB 106-7 Shelf	106	1
RB 116-7	100001001600	RB 116-7 Shelf	116	1
RB 166-7	100001006600	RB 166-7 Shelf	166	1
RB 216-7	100002001600	RB 216-7 Shelf	216	1
RTT 62	100090622000	RTT 62 Shelf support, divisible		1

Lock grid spacing 5.00 mm

In connection with at least two shelf supports (RTT) the shelf becomes a shelving system. The additional levels prevent cables from criss-crossing and therefore destroying each other, whilst also avoiding excessive friction. The shelving system can be pre-assembled on request.

Type	Dimensions in mm	
	TI	

RTT 62	8.00	
--------	------	--

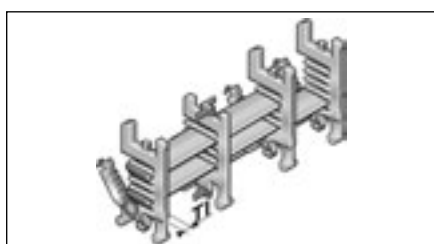

Shelving system

MP 62.2 - Accessories

Frame ridge connector



Frame ridge connector

Type	Order no.	Description	Pack
RSV 62	062000009600	RSV 62 Frame ridge connector	1
RSV 62 A	062000009800	RSV 62 Aluminium frame ridge connector	1

For frame ridges wider than 246 mm, we recommend the use of frame ridge connectors. These prevent deformation to the frame ridge under large amounts of additional weight of the chain assembly.



Frame ridge connector

Type	TI	Dimensions in mm
RSV 62	8.00	

Strain relief RS-ZL

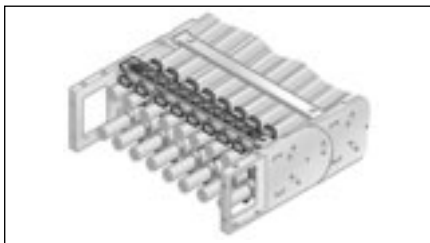

Strain relief RS-ZL

Type	Order no.	for inside width	Pack
RS-ZL 118-7	072011800010	118 mm	1
RS-ZL 143-7	072014300010	143 mm	1
RS-ZL 168-7	072016800010	168 mm	1
RS-ZL 193-7	072019300010	193 mm	1
RS-ZL 218-7	072021800010	218 mm	1
RS-ZL 243-7	072024300010	243 mm	1

Frame ridge strain relief that can be permanently integrated in the chain brackets. Tailored to all frame ridge widths up to 243 mm. May be mounted on the inside and outside bend at both ends of the chain.



MP 62.2 - Accessories

Strain relief with BAK



Strain relief with hooped clamps

Type	Order no.	Description	Ø in mm	Pack
C-rail	81661610	C-profile rail		1
BAK 14	81661002	BAK 14 Hooped clamp	6-14	1
BAK 18	81661004	BAK 18 Hooped clamp	14-18	1
BAK 22	81661006	BAK 22 Hooped clamp	18-22	1
BAK 26	81661008	BAK 26 Hooped clamp	22-26	1
BAK 30	81661010	BAK 30 Hooped clamp	26-30	1
BAK 14/2	81661012	BAK 14/2 Hooped clamp	10-14	1
BAK 18/2	81661014	BAK 18/2 Hooped clamp	14-18	1
BAK 22/2	81661016	BAK 22/2 Hooped clamp	18-22	1
BAK 26/2	81661018	BAK 26/2 Hooped clamp	22-26	1
BAK 12/3	81661020	BAK 12/3 Hooped clamp	9-12	1
BAK 14/3	81661022	BAK 14/3 Hooped clamp	12-14	1
BAK 16/3	81661024	BAK 16/3 Hooped clamp	14-16	1
BAK 18/3	81661026	BAK 18/3 Hooped clamp	16-18	1
BAK 20/3	81661028	BAK 20/3 Hooped clamp	18-20	1
BAK 22/3	81661030	BAK 22/3 Hooped clamp	20-22	1

Strain relief plates that can be permanently integrated in the chain brackets. Available in all widths (including individual widths in aluminium frame ridges). May be mounted on the inside and outside bend at both ends of the chain. The chain configuration can be fixed using hooped clamps that are available in different sizes. Material: Galvanised steel
Please indicate chain type and inside width when ordering.

Back radius

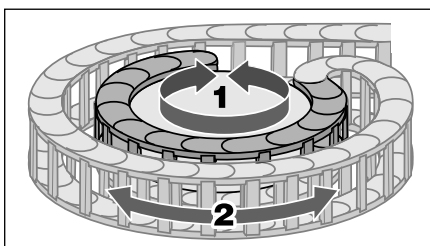

Rotary movement

Type	Order no.	Radius	Back Radius	Pack
SR 62.2 (RÜ300/R300) left	62200030060	300 mm	300 mm	1
SR 62.2 (RÜ300/R300) right	62200030062	300 mm	300 mm	1

Side links with forward radius (R) and back radius (Rü) permit movement in two directions. Areas of application include rotary movements and low-lying chain brackets. Please note the different side links for the left and right side run!

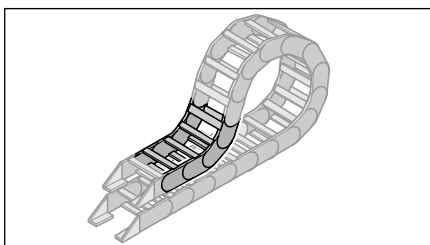

Low-lying chain bracket

MP 62.2 - Accessories

Assembly

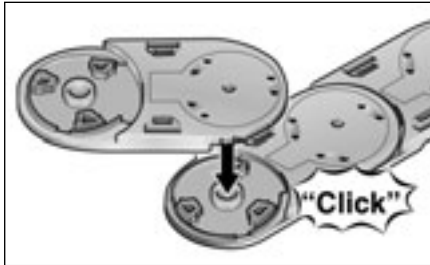

Step 1

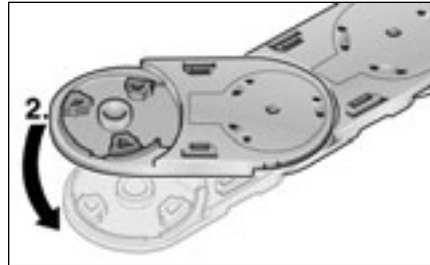

Step 2

The heavy-duty connection between the frame ridge and side wall has a positive fit. Both ends of the frame ridges are introduced evenly into the slots in the side links. The frame ridges are held secure by pressing in the frame ridge locks. Forces are transmitted solely through the slots on the frame ridge end or on the side link.

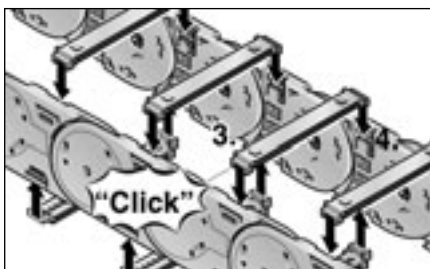

Step 3

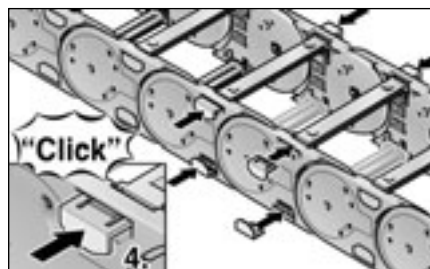

Step 4

Disassembly

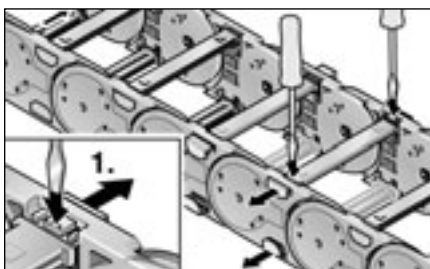

Step 1

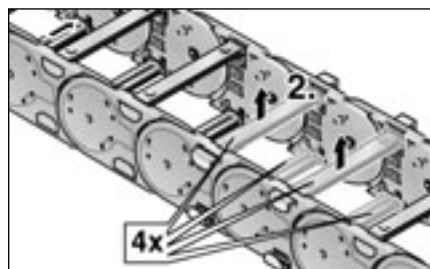

Step 2

Disassembly is effected in the reverse sequence to assembly. Loosen the locks until the frame ridges are released.

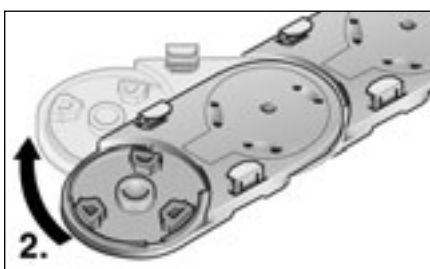

Step 3

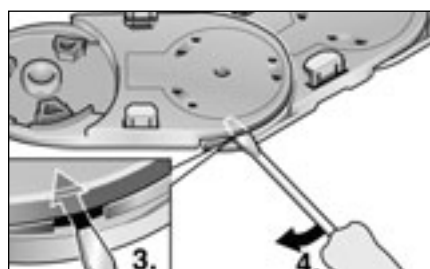

Step 4