

CABLE DRAG CHAIN SYSTEMS

MultiLine

MP 26

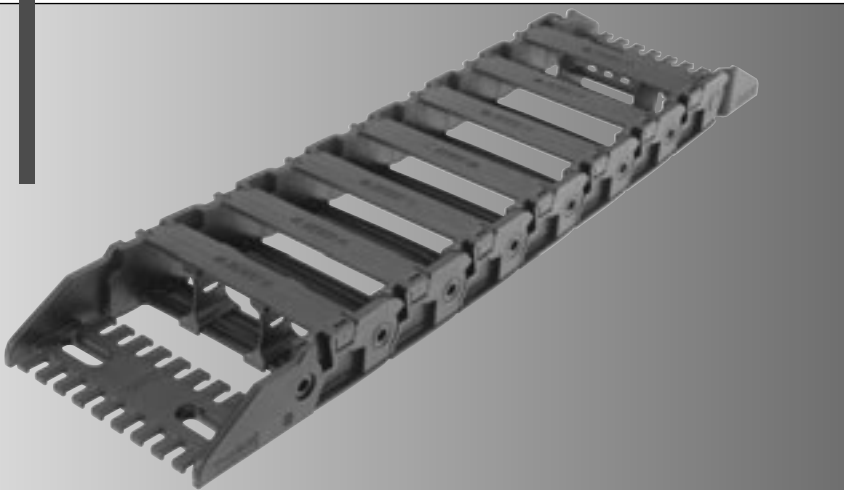



MP 26 - MultiLine

Order variants

Style (order code)						
Configuration (order code)						
Radius (order code)						
in mm						
Internal width (order code)						
in mm						
External width						
in mm						
MP 26 026	44	26	026	40	040	
MP 26 037	55	37	037	50	050	
MP 26 062	80	62	062	70	070	
MP 26 087	105	87	087	95	095	
MP 26 101	119	101	101	120	120	
MP 26 125	143	125	125	150	150	
				200	200	0
				250	250	7
						9

Order number:	0260			0			0
----------------------	------	--	--	---	--	--	---

Configuration:

0 crossbar every link; w/bias

Style:

0 Standard (PA)
 7 ESD (PA)
 9 Special version

Sample order

0260 026 040 0000

Inside width = 26 mm

Radius = 40 mm

Configuration = 0

Style = 0

Ideal operating conditions

- Compact dimensions with opening cover in inside bend
- Quiet operation
- High stability
- Flexible internal separation
- Rotated 90°, unsupported

Alternative chain type

- MP 3000
Version with/without bias
- MP 25 G closed series
- MP 32
opens on both sides
variable widths
greater stresses
flange connection (KA-F)
back radii

Features

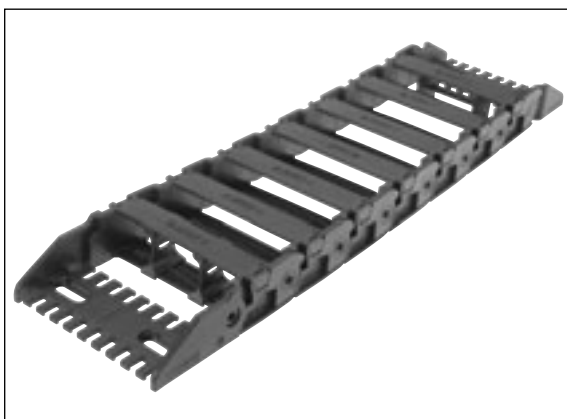

Radii with medium bias (R) for all applications



H-shelf for easy cable separation in the chain window



Integratable separator for cable separation



Chain bracket with metal inserts and strain relief



Frame ridges can be folded up on one side



Plug-in shelf system for reliable cable guidance



ZL strain relief plate

MP 26 - MultiLine

Technical data

Chain link dimensions

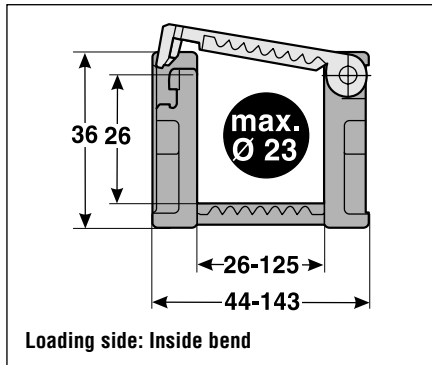

Material properties

Service temperature: -30 to +120 °C
 Gliding friction factor: 0.30
 Static friction factor: 0.45
 Fire classification: in conformity with UL94 HB
 ESD material: CE Ex II 2 GD

Other material properties on request

Technical specifications

Travel distance, gliding, L_g : 60 m
 Travel distance, self-supporting, L_s : see diagram
 Travel distance, vertical, hanging, L_{vh} : 40 m
 Travel distance, vertical, upright, L_{vu} : 3 m
 Rotated 90°, self-supporting, L_{sg} : 0.7 m
 Speed, gliding, V_g : 3 m/s
 Speed, self-supporting, V_s : 6 m/s
 Acceleration, gliding, a_g : 10 m/s²
 Acceleration, self-supporting, a_s : 15 m/s²

Unsupported length

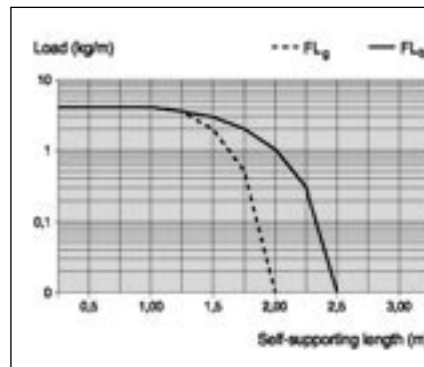
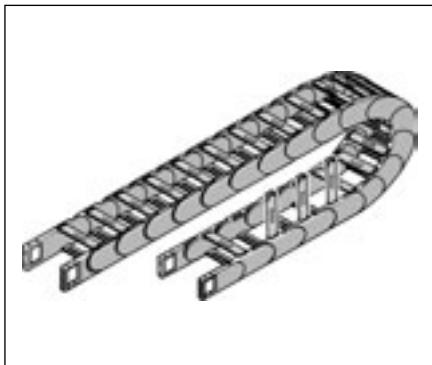

FL_g :
 Ideal installation situation for high stresses at the limit of the max. travel parameters. In this range the chain upper run is still biased, straight or has a max. sag of 10 – 50 mm depending on the type of chain.

FL_b :
 Satisfactory installation position for many applications working in the lower to middle range of the max. travel parameters. Depending on the chain type, the sag of the chain upper run is > 10 – 50 mm but less than the max. sag.

If the sag is greater than FL_b , the arrangement is unsuitable and should be avoided. Please choose a more stable murrplastik cable drag chain.

Determining the chain length

Determining the chain length

$$\text{Length} = \frac{L}{2} + \pi \times R + 2 \times T + E$$

≈ 1 m chain = 20 x 50 mm links

The fixed point of the cable drag chain should be connected in the middle of the travel distance. This arrangement gives the shortest connection between the fixed point and the moving consumer and thus the most efficient chain length.

L = Travel distance
 R = Radius
 T = Pitch
 E = Distance between entry point and middle of travel distance

Installation dimensions (in mm)

Radius R	40	50	70	95	120	150	200	250
Outside height of chain link (H_c)	36	36	36	36	36	36	36	36
Height of bend (H)	116	136	176	226	276	336	436	536
Height of moving end connection (H_{MA})	80	100	140	190	240	300	400	500
Safety margin (S)	70	70	70	70	70	70	70	70
Installation height (H_s)	186	206	246	296	346	406	506	606
Arc projection (M_L)	108	118	138	163	188	218	268	318
Bend length (L_b)	232	264	326	405	483	578	735	892



MP 26 - MultiLine

Chain bracket

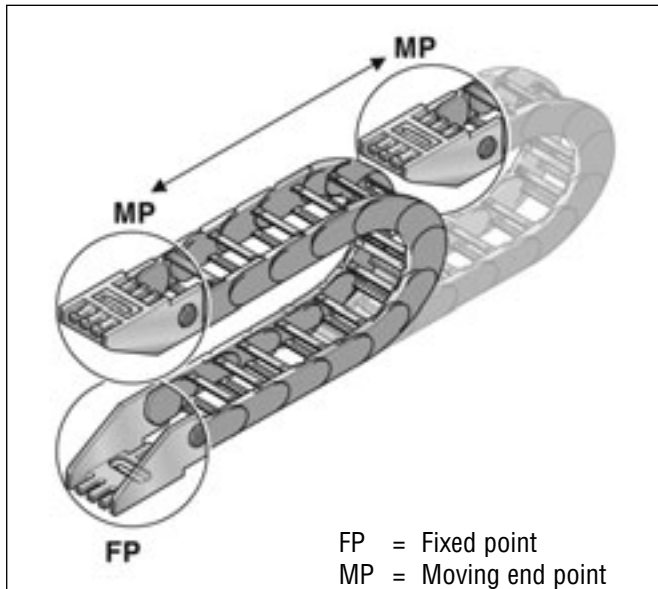

Chain bracket



Top



Bottom

Chain bracket

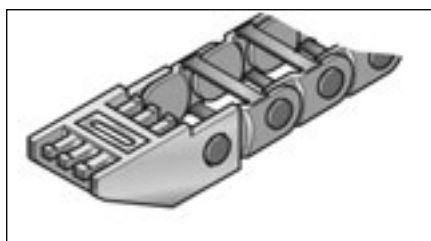

Type	Order no.	for inside width	Pack
KA/Z 26026 Female end	026000005000	26	1
KA/Z 26026 Male end	026000005100	26	1
KA/Z 26037 Female end	026000005200	37	1
KA/Z 26037 Male end	026000005300	37	1
KA/Z 26062 Female end	026000005400	62	1
KA/Z 26062 Male end	026000005500	62	1
KA/Z 26087 Female end	026000005600	87	1
KA/Z 26087 Male end	026000005700	87	1
KA/Z 26101 Female end	026000005800	101	1
KA/Z 26101 Male end	026000005900	101	1
KA/Z 26125 Female end	026000006000	125	1
KA/Z 26125 Male end	026000006100	125	1

The chain bracket, type KA/Z, is an all plastics part with extrusion coated metal insert. The bracket is precisely adjusted to the respective chain width and only needs to be snapped in at the chain link. Please order one male and one female end bracket for each chain. The brackets should be fastened with M6 screws. The cables or conduits should be fastened with cable ties on the integrated strain relief of the chain bracket.

MP 26 - MultiLine

Chain bracket

Dimensions in mm

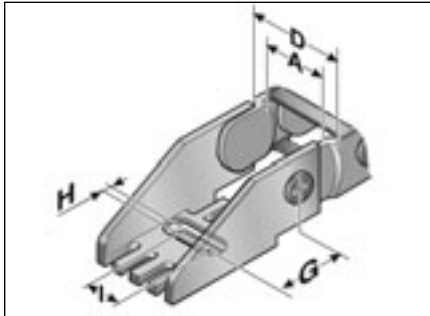

Type	A	D	G	H Ø	I
KA/Z 26026 Female end	26.00	44.00	34.50	6.50	18.50
KA/Z 26026 Male end	26.00	44.00	36.00	6.50	18.50

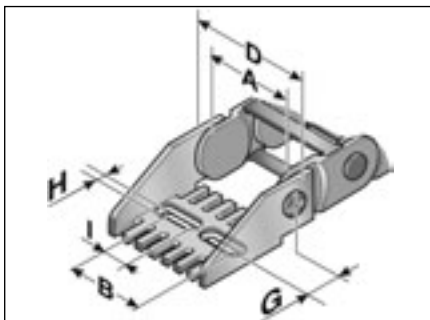

Type	A	B	D	G	H Ø	I
KA/Z 26037 Female end	37.00	30.00	55.00	34.50	6.50	7.50
KA/Z 26037 Male end	37.00	30.00	55.00	36.00	6.50	7.50
KA/Z 26062 Female end	62.00	55.00	80.00	34.50	6.50	18.50
KA/Z 26062 Male end	62.00	55.00	80.00	36.00	6.50	18.50
KA/Z 26087 Female end	87.00	80.00	105.00	34.50	6.50	18.50
KA/Z 26087 Male end	87.00	80.00	105.00	36.00	6.50	18.50
KA/Z 26101 Female end	101.00	94.00	119.00	34.50	6.50	18.50
KA/Z 26101 Male end	101.00	94.00	119.00	36.00	6.50	18.50
KA/Z 26125 Female end	125.00	118.00	143.00	34.50	6.50	18.50
KA/Z 26125 Male end	125.00	118.00	143.00	36.00	6.50	18.50



MP 26 - Accessories

Separator



Separator

Type	Order no.	Description	Pack
TR 3000	030000009000	Separator movable	1
TR 3001	030000009200	Separator lockable	1

Lock grid spacing 3.00 mm

We recommend that separators are used if multiple round cables or conduits with differing diameters are to be installed. An offset configuration of the separators is advisable. The fixed lockable separator must be used for side-mounted cable drag chains to prevent the separator from slipping down.



Separator

Type	Dimensions in mm			
	Tl	H	H1	H2
TR 3000	1.50	2.50	12.90	12.90
TR 3001	1.50	2.50	12.90	12.90

H-shaped shelf unit

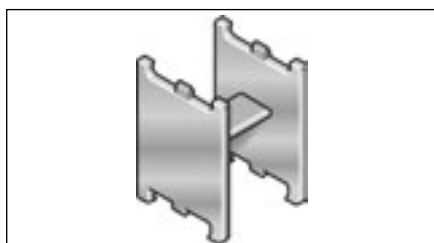

H-shaped shelf unit

Type	Order no.	Description	Pack
RE 2615	100000261510	RE 2615 Shelf unit, H-shaped	1
RE 2627	100000262710	RE 2627 Shelf unit, H-shaped	1
RE 2632	100000263210	RE 2632 Shelf unit, H-shaped	1
RE 2651	100000265110	RE 2651 Shelf unit, H-shaped	1

Lock grid spacing 3.00 mm

Insert to obtain additional levels in pre-defined distances.

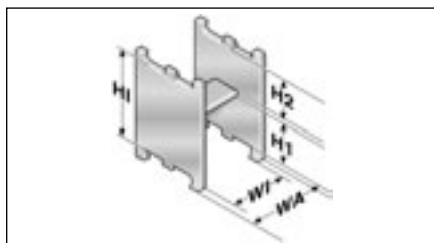

H-shaped shelf unit

Type	Dimensions in mm				
	WA	WI	H1	H2	HI
RE 2615	17.50	12.50	13.70	9.60	26.00
RE 2627	29.50	24.50	13.70	9.60	26.00
RE 2632	37.00	32.00	17.50	6.00	26.00
RE 2651	53.50	48.50	13.70	9.60	26.00

MP 26 - Accessories

Shelving system	Type	Order no.	Description	Width in mm	Pack
	RB 037	100000003700	RB 037 Shelf	37	1
	RB 062	100000006200	RB 062 Shelf	62	1
	RB 086	100000008600	RB 086 Shelf	86	1
	RB 101	100000010100	RB 101 Shelf	101	1
	RB 125	100000012500	RB 125 Shelf	125	1
Lock grid spacing 3.00 mm					

Shelving system

The shelf must be used with a minimum of two separators to create a shelving system. The additional levels prevent cables from criss-crossing and therefore destroying each other, whilst also avoiding excessive friction. The shelves are matched to the available chain widths.



MP 26 - MultiLine

Assembly

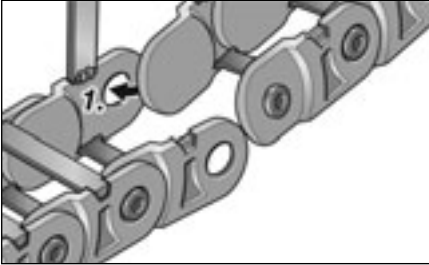

Step 1

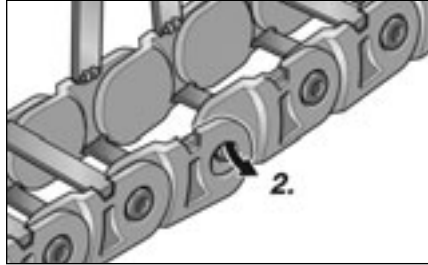

Step 2

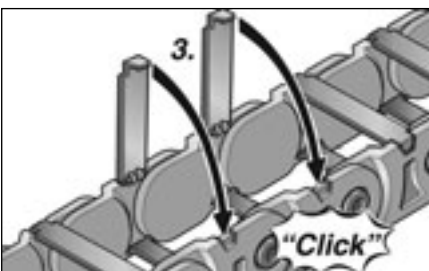

Step 3

Disassembly

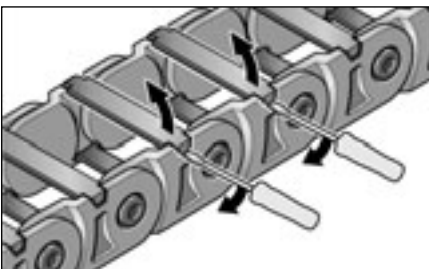

Step 1

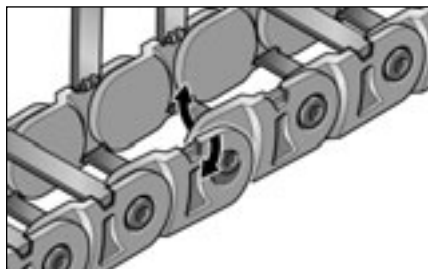

Step 2