

CABLE DRAG CHAIN SYSTEMS

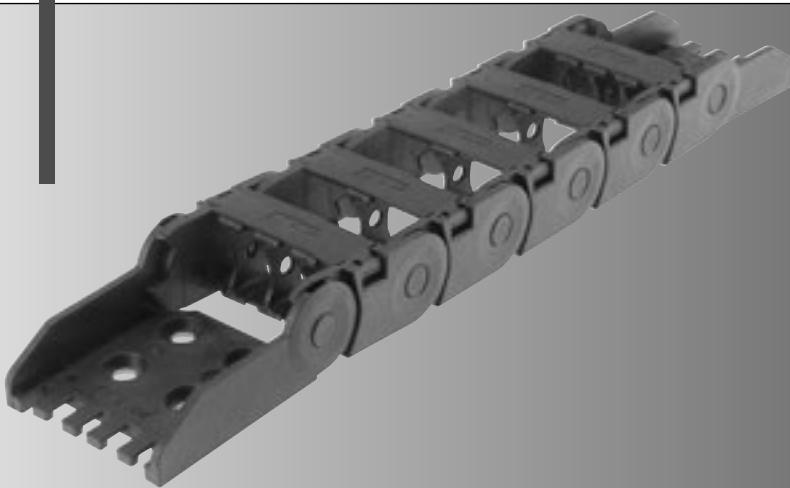

MultiLine

MP 18.2



MP 18.2 - MultiLine

Order variants

Style (order code)						
Configuration (order code)						
Radius (order code)						
in mm						
Internal width (order code)						
in mm						
External width						
in mm						
MP18.2 018	31	18	018			
MP18.2 025	38	25	025	28	028	
MP18.2 037	50	37	037	38	038	0
MP18.2 050	63	50	050	48	048	7
MP18.2 070	83	70	070	78	078	9

Order number:	0182			0			0
----------------------	------	--	--	---	--	--	---

Configuration:

0 crossbar every link; w/bias

Style:

0 Standard (PA)
 7 ESD (PA)
 9 Special version

Sample order

0182 018 028 0000

Inside width = 18 mm

Radius = 28 mm

Configuration = 0

Style = 0

Ideal operating conditions

- Compact dimensions with opening cover in inside bend
- Quiet operation
- High stability
- Flexible internal separation
- Unsupported arrangement
- Rotated 90°, unsupported

Alternative chain type

- MP 18.1
Opening cover in outside bend, gliding application
- MP 2000 Easier to use
- MP 26 / MP 3000
Greater self-supported lengths

Features

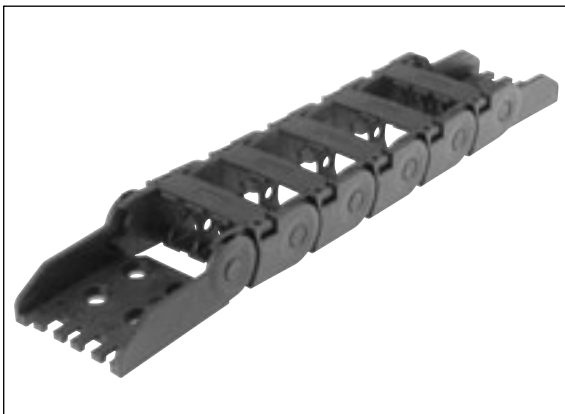

Radii with medium bias (R) for all applications



ESD cable drag chains for use in areas at risk of explosion



Back radius combinations



Integratable separator for cable separation



ESD cable drag chains for use in areas of electrostatic discharge



Chain bracket with metal inserts and strain relief



Frame ridges can be folded up on one side

MP 18.2 - MultiLine

Technical data

Chain link dimensions

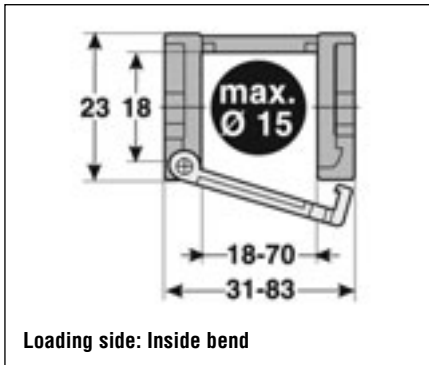

Material properties

Service temperature: -30 to +120 °C
 Gliding friction factor: 0,30
 Static friction factor: 0,45
 Fire classification: in conformity with UL94 HB
 ESD material: CE Ex II 2 GD

Other material properties on request

Technical specifications

Travel distance, gliding, L_g : not recommended
 Travel distance, self-supporting, L_s : see diagram
 Travel distance, vertical, hanging, L_{vh} : 8 m
 Travel distance, vertical, upright, L_{vu} : 3 m
 Rotated 90°, self-supporting, L_{sg} : 0.5 m
 Speed, self-supporting, V_i : 5 m/s
 Acceleration, self-supporting, a_i : 5 m/s²

Unsupported length

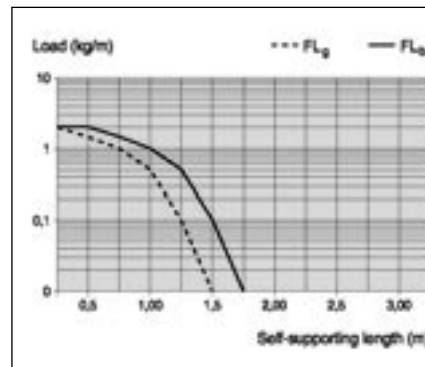
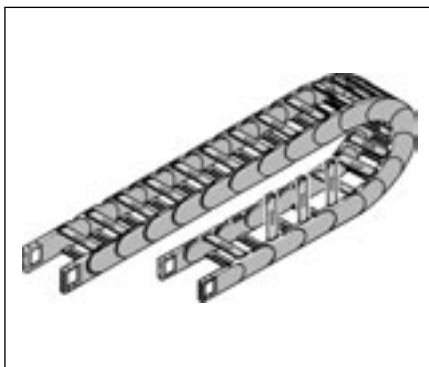

FL_g :
 Ideal installation situation for high stresses at the limit of the max. travel parameters. In this range the chain upper run is still biased, straight or has a max. sag of 10 – 50 mm depending on the type of chain.

FL_b :
 Satisfactory installation position for many applications working in the lower to middle range of the max. travel parameters. Depending on the chain type, the sag of the chain upper run is > 10 – 50 mm but less than the max. sag.

If the sag is greater than FL_b , the arrangement is unsuitable and should be avoided. Please choose a more stable murrplastik cable drag chain.

Determining the chain length

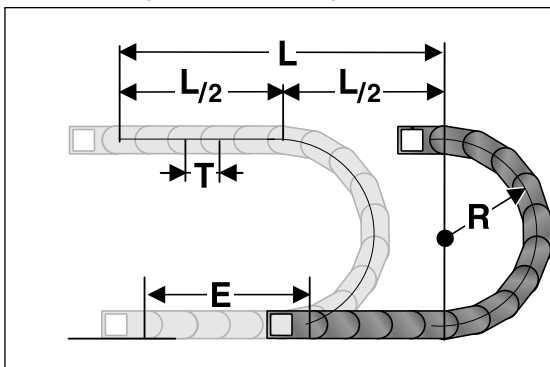

Determining the chain length

$$\text{Length} = \frac{L}{2} + \pi \times R + 2 \times T + E$$

≈ 1 m chain = 30 x 33 mm links

The fixed point of the cable drag chain should be connected in the middle of the travel distance. This arrangement gives the shortest connection between the fixed point and the moving consumer and thus the most efficient chain length.

Installation dimensions (in mm)

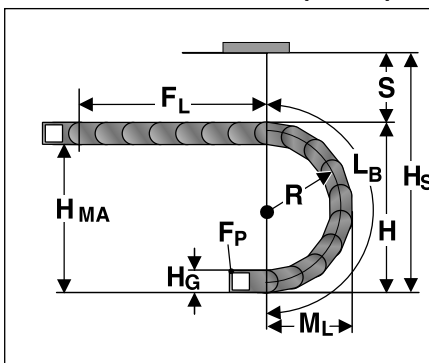

Radius R	28	38	48	78
Outside height of chain link (H_e)	23	23	23	23
Height of bend (H)	79	99	119	179
Height of moving end connection (H_{MA})	56	76	96	156
Safety margin (S)	30	30	30	30
Installation height (H_i)	109	129	149	209
Arc projection (M_i)	73	83	93	123
Bend length (L_b)	157	188	220	314



MP 18.2 - MultiLine

Chain bracket

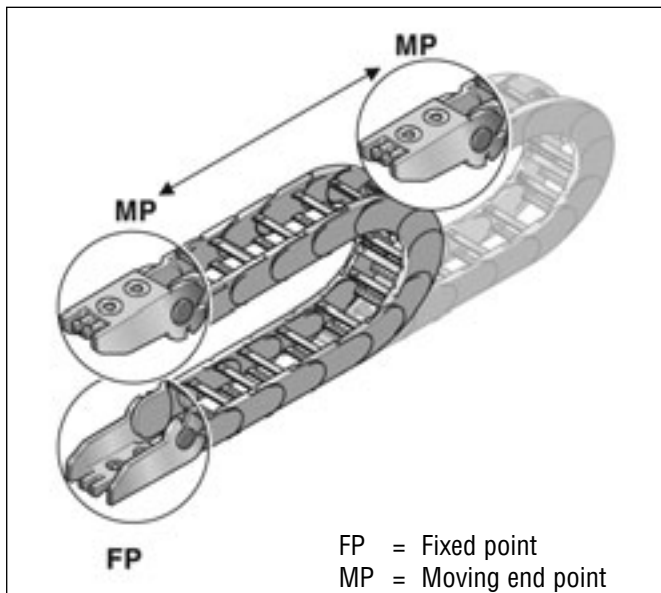

Chain bracket



Top 0°



Bottom 0°



Top 90°



Bottom 90°

Chain bracket

Type

Order no.

Pack

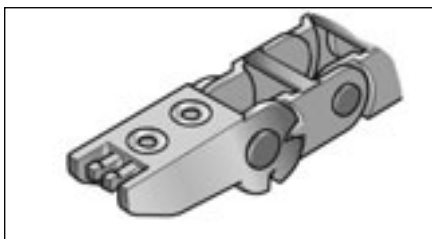

KA/Z 18018 Female end	018100005000	1
KA/Z 18018 Male end	018100005100	1
KA/Z 18025 Female end	018100005200	1
KA/Z 18025 Male end	018100005300	1
KA/Z 18037 Female end	018100005400	1
KA/Z 18037 Male end	018100005500	1
KA/Z 18050 Female end	018100005600	1
KA/Z 18050 Male end	018100005700	1
KA/Z 18070 Female end	018100005800	1
KA/Z 18070 Male end	018100005900	1

The chain bracket is an all plastics part with extrusion coated metal insert. The bracket is precisely adjusted to the respective chain width and only needs to be snapped in at the chain link. Please order one male and one female end bracket for each chain. The brackets should be fastened with M5 screws. The cables or conduits may be fastened with cable ties on the integrated strain relief of the chain bracket.

MP 18.2 - MultiLine

Chain bracket

Dimensions in mm

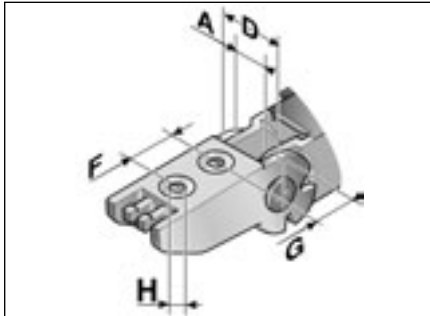

Type	A	D	F	G	H Ø
KA/Z 18018 Female end	18.40	30.00	19.00	10.50	5.50
KA/Z 18018 Male end	18.40	30.00	19.00	8.50	5.50
KA/Z 18025 Female end	25.40	37.00	19.00	10.50	5.50
KA/Z 18025 Male end	25.40	37.00	19.00	8.50	5.50

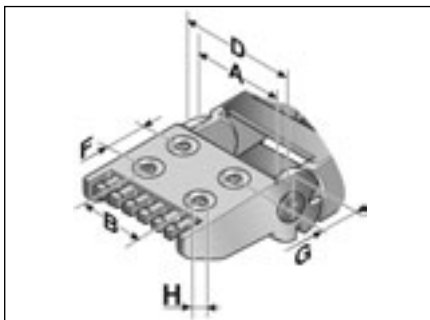

Type	A	B	D	F	G	H Ø
KA/Z 18037 Female end	37.40	20.00	49.00	19.00	10.50	5.50
KA/Z 18037 Male end	37.40	20.00	49.00	19.00	8.50	5.50
KA/Z 18050 Female end	50.40	34.00	62.00	19.00	10.50	5.50
KA/Z 18050 Male end	50.40	34.00	62.00	19.00	8.50	5.50
KA/Z 18070 Female end	70.40	48.00	82.00	19.00	10.50	5.50
KA/Z 18070 Male end	70.40	48.00	82.00	19.00	8.50	5.50

Separator

Type Order no. Description Pack



Separator

TR 14/18	018200009000	Separator	1
----------	--------------	-----------	---

We recommend that separators are used if multiple round cables or conduits with differing diameters are to be installed.
An offset configuration of the separators is advisable.

Type TI Dimensions in mm



Separator

TR 14/18	1.50
----------	------



MP 18.2 - MultiLine

Assembly

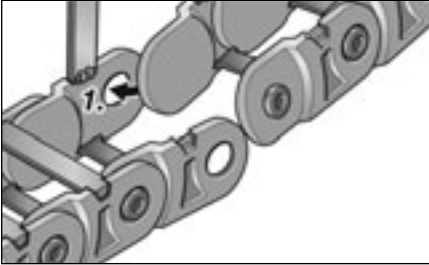

Step 1

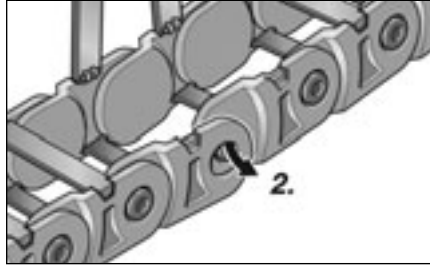

Step 2

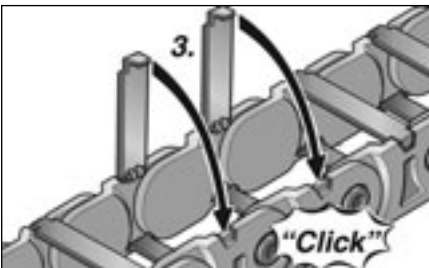

Step 3

Disassembly

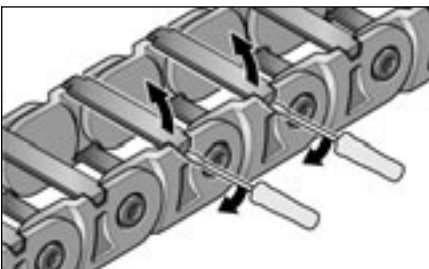

Step 1

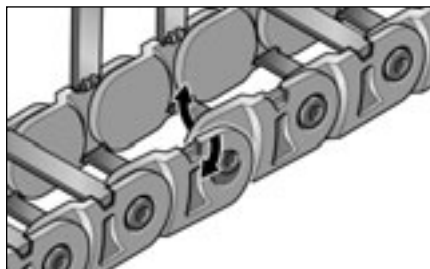

Step 2